

# AX1500 XPON ONT With Voice

BT-G716AX

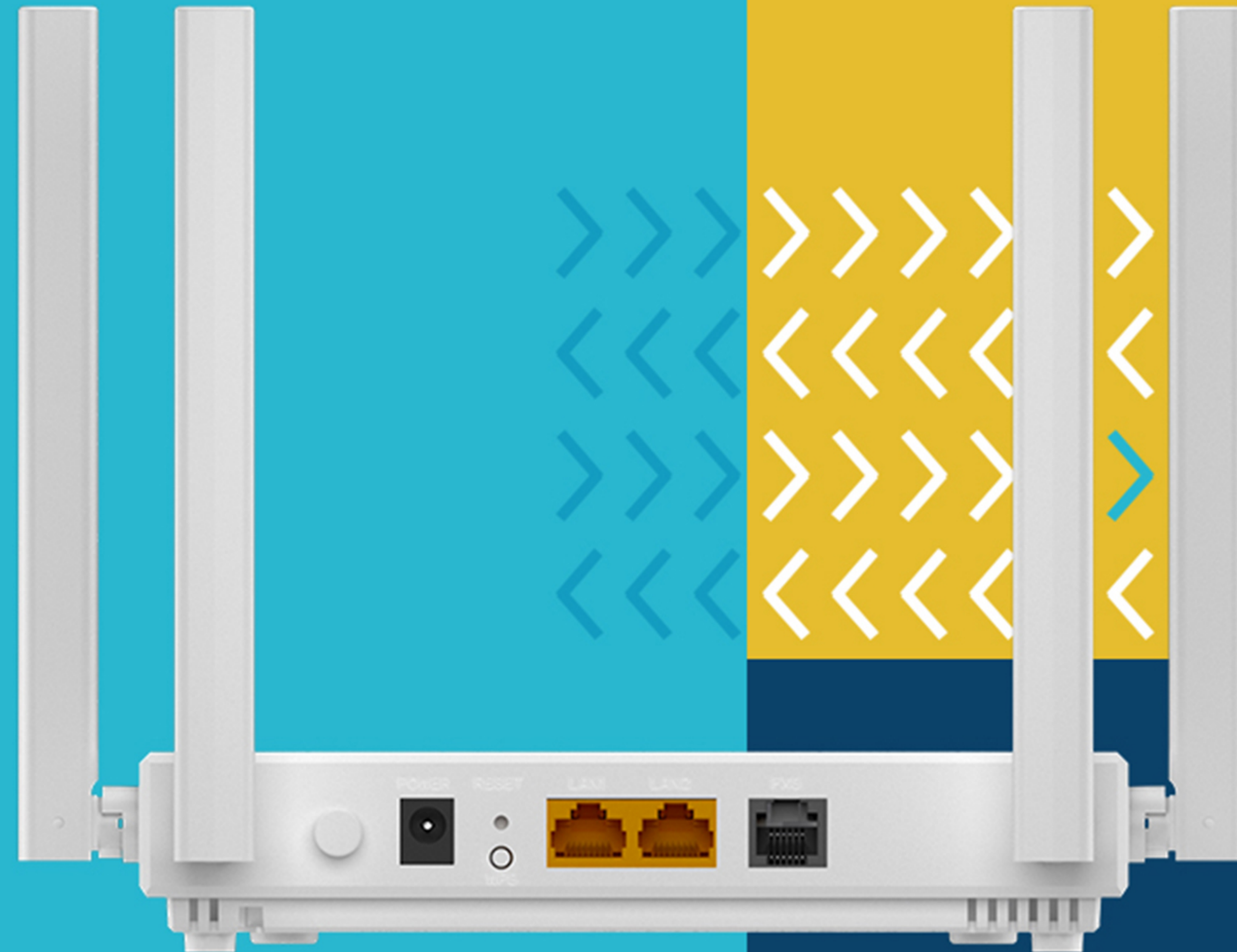

802.11ax



Dual Band



VoIP



Parental Control



IPv6







# Access to Fiber Optical Network

Support downstream 2.5Gbps and upstream to 1.25Gbps with transmission distance up to 20km. Higher bandwidth support makes it possible to integrate and provide more additional services with the same device.

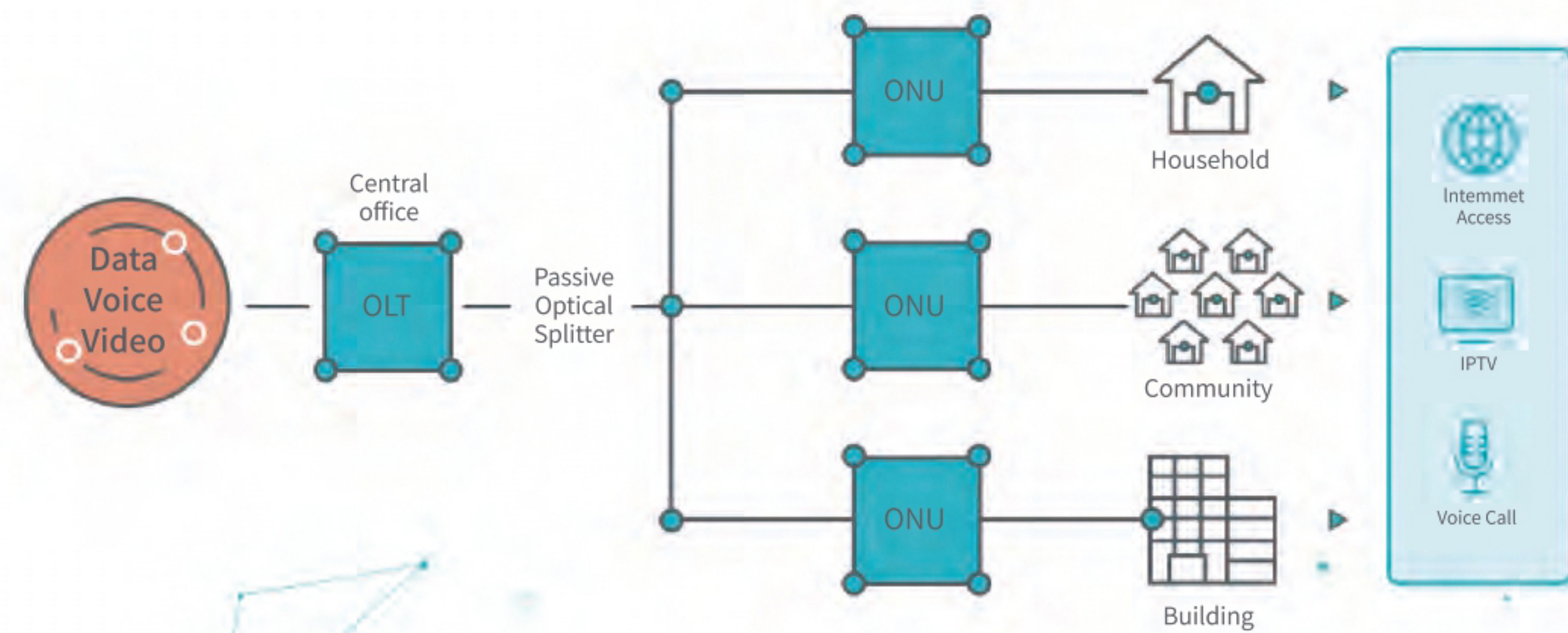

## Easy Remote Management

BT-G716AX support the ONT Management and Control Interface (OMCI), making it easy to configure, activate and manage remotely from an Optical Line Terminal(OLT).









# Specifications

## General

GPON Standards: ITU-T G.984.x

Distance: 20Km Max

Data Rates: Upstream:1.25Gbps, Downstream:2.5Gbps

Wireless Standards: IEEE 802.11ax/ac/n/a 5 GHz

IEEE 802.11n/b/g 2.4 GHz

Signal Rate: 5 GHz: 1201 Mbps(802.11ax),

2.4 GHz: 300 Mbps(802.11n)

Operation Frequency: 2.4GHz & 5GHz

Wireless Security: WEP/WPA2/WPA2 Mix/WPA3/WPA3 Transition

VOIP Standards: SIP (RFC3261), ITU-T G.729/G.722/G.711a/G.711

## Hardware

- Interfaces: 1 x SC/APC XPON Port  
2 x 10/100/1000Mbps LAN Ports  
1 x FXS Port

Buttons: WPS/WiFi Button, Reset Button

Power Supply: DC 12V 1A

Antenna: 4 x 5dBi Antennas

Dimensions (W X D X H): 170 x 105 x 31mm

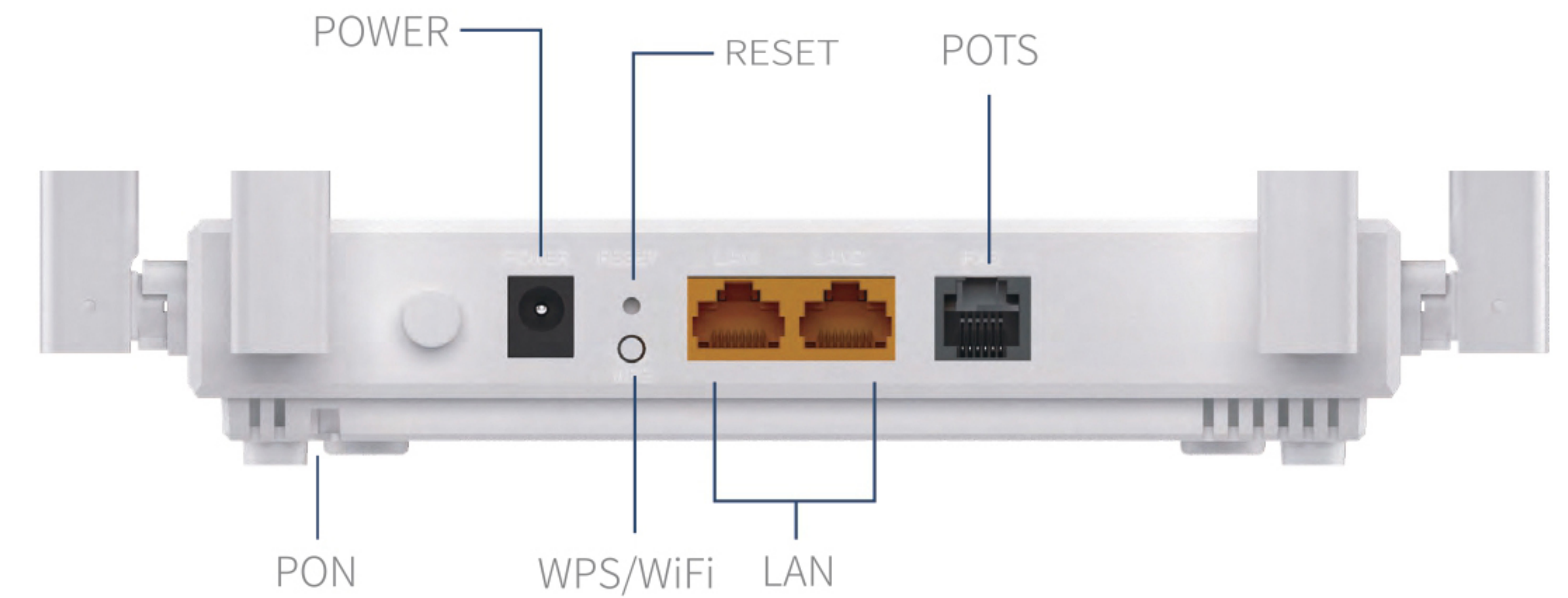



# Specifications

## Software Features

- WAN Type: Dynamic IP/Static IP/PPPoE
- DHCP: Server, Client, DHCP Client List, Address Reservation
- Quality of Service: WMM, Bandwidth Control
- Port Forwarding: Virtual Server, Port Triggering, UPnP, DMZ
- VLAN: 802.1Q tag VLAN, VLAN transparent mode/VLAN translation mode/VLAN trunk mode
- Access Control: Parental Control, Local Management Control, Host List, Access Schedule, Rule Management
- Firewall Security: DoS, SPI Firewall  
IP Address Filter/MAC Address Filter/Domain Filter  
IP and MAC Address Binding
- VOIP Features: One RJ-11 FXS ports for connecting to analog telephones Call forwarding, Call waiting, Call block, 3-way conference call, etc.
- Management: Access Control  
Local Management  
Remote Management
- Internet Protocol: IPv4,IPv6

## Environment

- Operating Temperature: 0°C~40°C (32°F~104°F)
- Storage Temperature: -40°C~70°C (-40°F~158°F)
- Relative Humidity: 10%~90%, non-condensing
- Storage Humidity: 5%~95%, non-condensing

## Package Contents

- 1 x XPON Router
- 1 x Quick Installation Guide
- 1 x Power Adapter
- 1 x Ethernet Cable

## Certifications

- CE, RoHS

